

## Natural gas engine combustion research based on bench test

CHEN BO, CHEN Ling-shan, Jiang Hui-hua, SUN QI, FU Zhi-yu

(College of Automotive, Shanghai University of Engineering Science, Shanghai201620, China)

**Abstract:** In this paper, mainly research on LNG(CNG) engine with outside-cylinder premixed combustion mode, the combustion mode can determine the gas engine emissions and power performance. There are three kinds of engine combustion -Lean combustion, Equivalent combustion and Mixed combustion mode by using equivalent combustion/lean burn combined. The innovation point lies in this paper is that this experiment adopts mixed combustion mode by burning strategy control, can be achieved in guarantee engine fuel economy, power performance, meet the requirements of Euro V combustion emissions regulations.

**Key words:** equivalent combustion, lean combustion, mixed combustion, combustion emissions

### I. INTRODUCTION

In recent years, along with the increasingly serious urban air pollution, more and more people pay attention to the the problem of environmental pollution, more and more persons are aware of the importance of environmental protection; Many cities such as Beijing and Shanghai have started fully uphold the Euro V combustion emissions regulations. Natural gas is a clean alternative fuel, compared with the traditional fuel, gas does not produce carbon smoke during burning, have relatively low NO<sub>x</sub>, CO and HC emissions, popularized in domestic, especially the field of city bus. Natural gas engines widely used Equivalent combustion and oxidation catalytic converter satisfies the requirement of Euro IV combustion emissions regulations. But face Euro V combustion emissions regulations, Equivalent combustion technology is difficult to juggle emission and power performance. This paper mainly has a study of Mixed combustion mode by using equivalent combustion/lean burn combined. This technique can be achieved in guarantee engine fuel economy, power performance, meet the requirements of Euro V combustion emissions regulations.

### II. The construction of the bench test

The construction of the natural gas engine bench test as shown in the figure below.

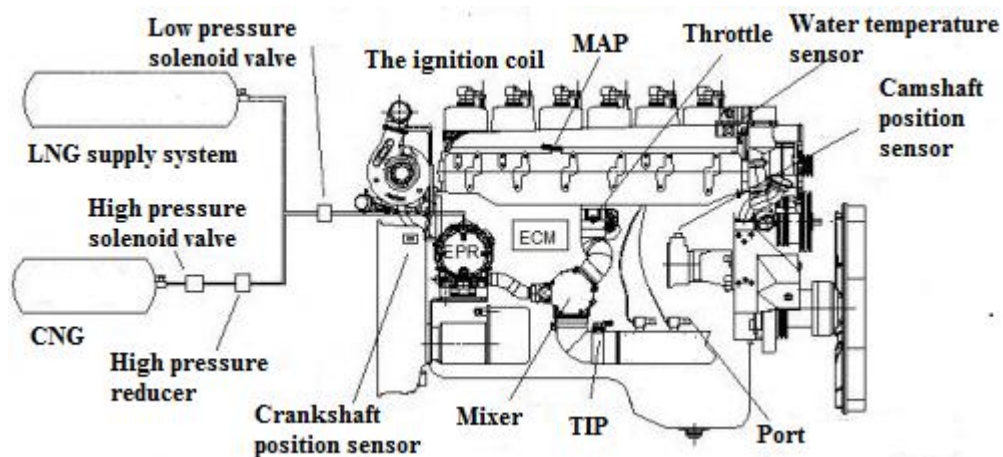

Fig1 Natural gas engine structure

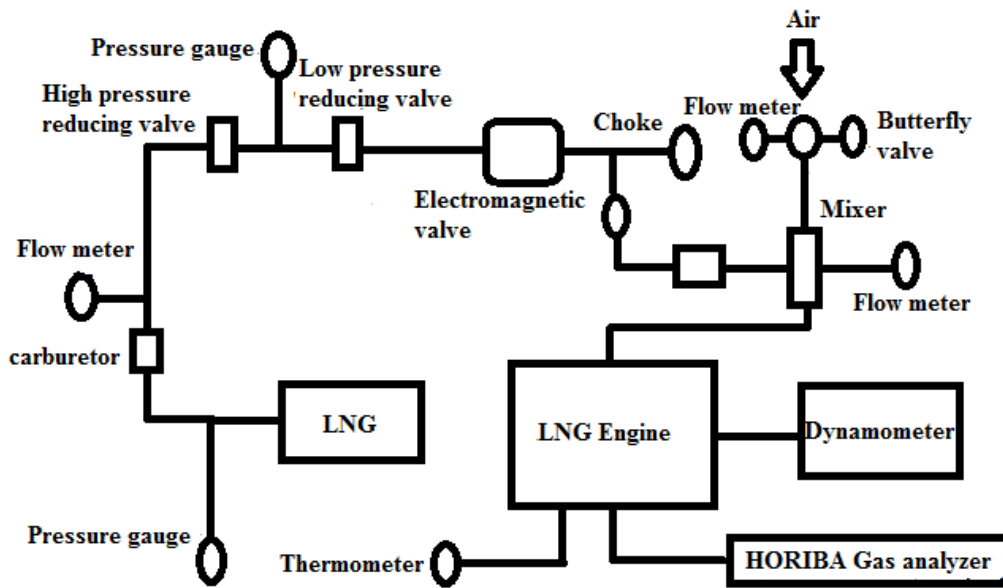

Fig 2 Bench experiment device

### III. Different combustion modes analysis

Equivalent combustion is to make the excess air coefficient increased from  $\lambda=1$  to  $\lambda$  which is far more than 1.1. By the theory of cycle thermal efficiency, heat efficiency  $\eta$  will be increased with the increase of adiabatic index  $K$  increased. The combustion products of natural gas is mainly composed of  $CO_2$ ,  $H_2O$ , etc. So, when the mixture is thicker, the proportion of the amount of Polyatomic molecule is bigger and the adiabatic index  $K$  is small. When the mixture is lean, the adiabatic index  $K$  increases. Theoretically, mixture is thinner,  $K$  bigger, the greater the thermal efficiency.

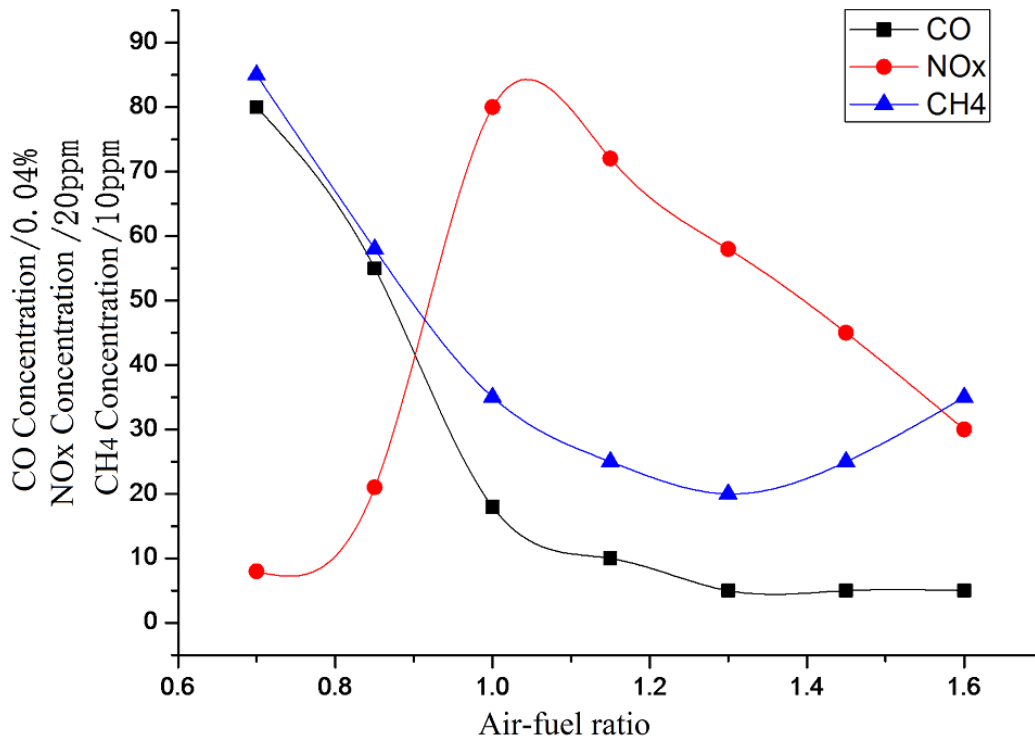

Fig 3 Combustion on different Air-fuel ratios effect on CO/HC/NO<sub>x</sub> emissions

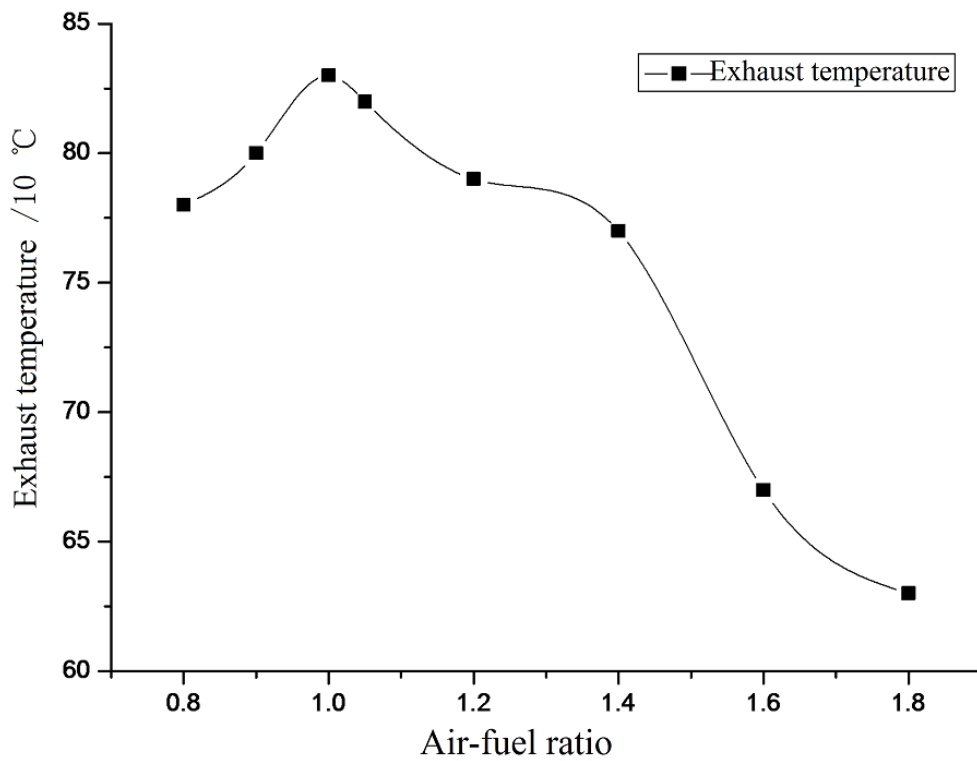

Fig 4 Combustion on different Air-fuel ratios effect on exhaust temperature

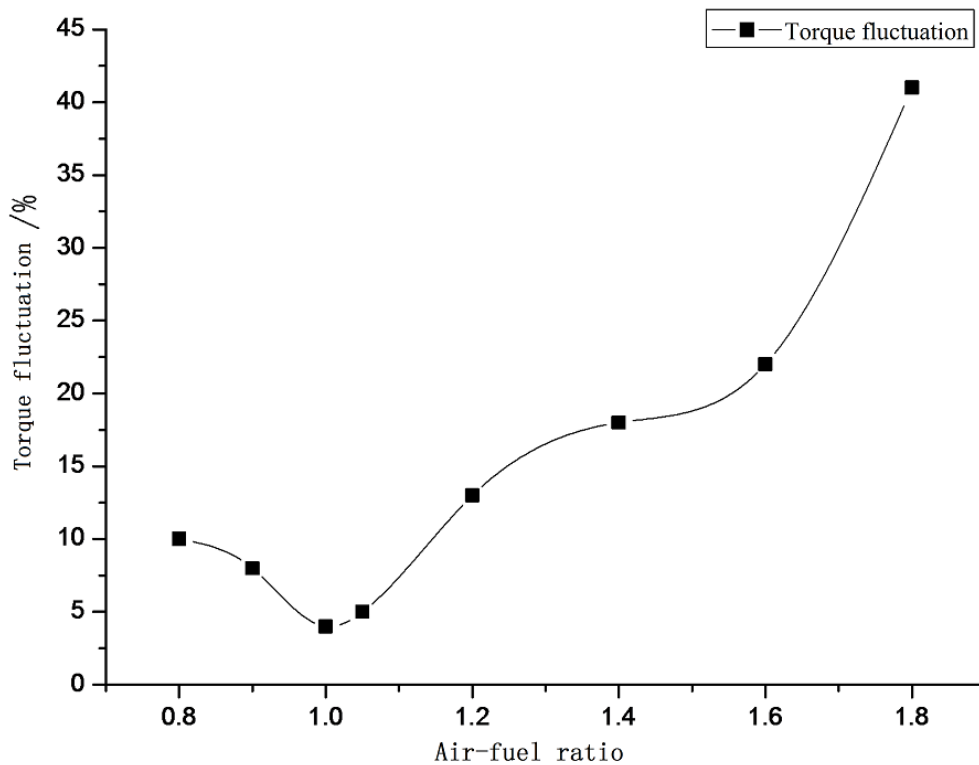

Fig 5 Combustion on different Air-fuel ratios effect on torque fluctuation

$\lambda$  distribution area of equivalent combustion and lean combustion:  $\lambda$  distribution area of equivalent combustion is  $\Lambda=1.3\sim 1.6$ .

#### IV. Comparisons of equivalent combustion and mixed combustion emissions

For LNG (CNG) engine, the air-fuel ratio determines the gas engine emissions and power performance. Mixed combustion mode by using equivalent combustion/lean burn combined, in the low load region, the equivalent combustion and three way catalytic converter to reduce the concentration of various pollutants in the exhaust, reduce the fluctuation cycle, improve vehicle driving; in high load area, through the lean combustion to reduce NO<sub>x</sub> original emissions, while reducing the heat load, improve the economic, the engine body without significant improvement can meet the state five emission and request driven nature.

$\lambda=1$  and  $\lambda >1$ , corresponding to equivalent combustion, lean combustion. Reasonably adjust the rareness combustion area, both engine heat load, emissions and acceleration. The transition region of equivalent combustion, lean combustion air-fuel ratio change quickly. To be able to in the process of equivalent combustion and lean combustion switch quickly and skip to control NO<sub>x</sub> and set the air-fuel ratio of the area, skip the area of  $\lambda= 1.05 \sim 1.3$ .

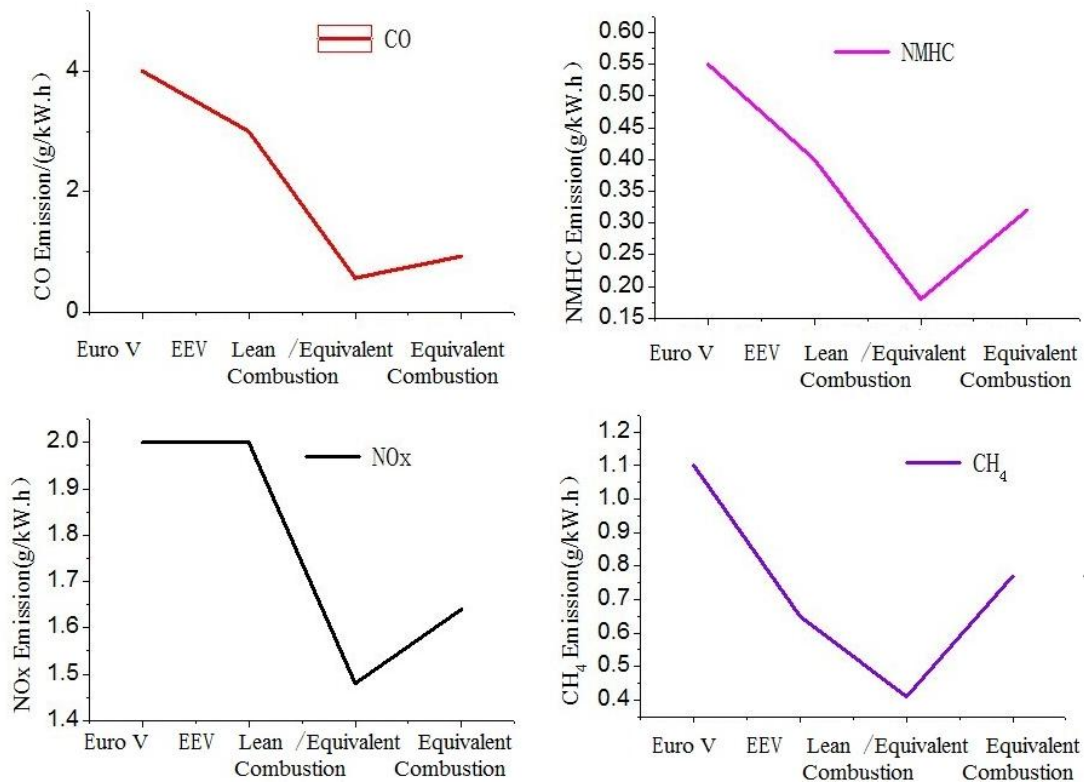

Fig 6 Equivalent combustion and mixed combustion emissions

#### V. The control of Air-fuel ratio

Gas engine output torque depends on the air flow, air-fuel ratio, ignition advance Angle. Equivalent switching and rarefied combustion process, through the air-fuel ratio step change to reduce NO<sub>x</sub> emissions. In order to realize smooth transition, the mutations in the inevitable requirement of air-fuel ratio of air flow rate and ignition advance Angle of mutations From figure describes the engine idle speed refueling door in the process of acceleration. Down the accelerator pedal is stepped on a degree is no longer changes. Small at first, the load and rotational speed, the engine work in the equivalent of burning zone, throttle and intake manifold pressure is small, the engine gradually speed up, when the engine over a certain speed and load mixture from thick to thin, quickly into equivalent combustion zone. Must keep the accelerator pedal position unchanged. In traditional engine which means that the volume remains the same, so when the

switch to the  $\lambda > 1$ , fuel injection quantity must be steep, torque significantly decreased. Solution to this problem is that when the switch to the  $\lambda$  increase the throttle opening. ECU under a thin air-fuel ratio accordingly increasing the flow of air and gas flow rate, torque and to keep the level of before the switch to the mixture. In rarefied combustion and burning equivalent two different regions, respectively to the throttle opening, air-fuel ratio, ignition advance Angle, charging efficiency, such as pulse spectra calibration, ensure the air-fuel ratio  $\lambda$  when switching torque impact.

Table 1 Equivalent combustion and mixed combustion emissions

<b>Technical route</b>	Equivalent combustion+Mixed combustion	Equivalent Combustion
Emissions	General	Bad
	Meet the Euro V and EEV emissions	Meet the Euro III emissions
Economy	General	Bad
	General	Low
Heat load	Slightly higher than that of diesel engine exhaust temperature	Exhaust temperature slightly higher than the diesel engine
Cost	Low	Low

## VI. Conclusion

Beijing and Shanghai and other cities have begun to implement the Euro V high standards of emission regulations. As engine fuel, nature gas, compared with the conventional fuels, do not produce carbon smoke, have relatively low NO<sub>x</sub>, CO and HC emissions of pollutants, such as extremely clean, thus obtained the popularization and promotion, especially in the field of buses in the city, has certain market scales and the prospect of continued development. At present, most of the natural gas engine with equivalent combustion technology and oxidation catalytic converter, satisfy the requirement of Euro IV emissions. However, advancing with The Times, in the face of increasingly severe Euro V emission regulations, the equivalent combustion technology can't meet the emission and power performance. Engine bench test in this paper, elaborated the mixed combustion mode by using equivalent combustion/lean burn combined technology, this technology can be under the condition of the engine body does not make significant improvements, both meets the Euro V combustion emission standard and guarantees good performance and fuel economy.

## References

- [1] Mathew D. Ruter, Daniel B. Olsen, Mark V. Scotto, Mark A. Perna. NO<sub>x</sub> reduction from a large bore natural gas engine via reformed natural gas prechamber fueling optimization. *Fuel*, 91, 2012:298-306
- [2] T. Korakianitis, A.M. Namasivayam, R.J. Crookes. Natural-gas fueled spark-ignition (SI) and compression-ignition (CI) engine performance and emissions. *Progress in Energy and Combustion Science*. 37, 2011:89-112
- [3] Mohand Said Lounici, Khaled Loubar, Mourad Balistrout, Mohand Tazerout. Investigation on heat transfer evaluation for a more efficient two-zone combustion model in the case of natural gas SI engines. *Applied Thermal Engineering*, 31, 2011:319-328
- [4] A.K. Amjad, R. Khoshbakhhi Saray, S.M.S. Mahmoudi, A. Rahimi. Availability analysis of n-heptane and natural gas blends combustion in HCCI engines. *Energy*, 36, 2011:6900-6909
- [5] M. Mansha, A. R Saleemi. Badar M. Ghauri. Kinetic models of natural gas combustion in an internal

combustion engine. Journal of Natural Gas Chemistry,19,2010: 6-14

**The Introduction of the first author:** Chen Bo, male, born 16 September 1991, postgraduate, studying at the Shanghai University of Engineering Science, Institute of automotive engineering, vehicle engineering. The main study direction: natural gas / diesel dual fuel engine. Address: Song jiang University City Long-teng Road No. 333. Postal code: 201620 Tel: 18818235962 E-mail: chenboshunli@163.com.

**The Introduction of the second author:** Chen Ling-shan, female, born in 1966, Professor of Shanghai University of Engineering Science. Research direction: automobile energy saving and emission control, the design of key auto parts . Address: Shanghai Song jiang University City Long-teng Road No. 333. Postal Code: 201620. Tel: 021-67791147. e-mail: bechenlsh@163.com. Education: Tianjin University bachelor, master, doctor graduate.